

# Колонны ВЭЖХ Mediterranea

## Технические характеристики

По вопросам продаж и поддержки обращайтесь:

Алматы (7273)495-231  
Ангарск (3955)60-70-56  
Архангельск (8182)63-90-72  
Астрахань (8512)99-46-04  
Барнаул (3852)73-04-60  
Белгород (4722)40-23-64  
Благовещенск (4162)22-76-07  
Брянск (4832)59-03-52  
Владивосток (423)249-28-31  
Владикавказ (8672)28-90-48  
Владимир (4922)49-43-18  
Волгоград (844)278-03-48  
Вологда (8172)26-41-59  
Воронеж (473)204-51-73  
Екатеринбург (343)384-55-89

Иваново (4932)77-34-06  
Ижевск (3412)26-03-58  
Иркутск (395)279-98-46  
Казань (843)206-01-48  
Калининград (4012)72-03-81  
Калуга (4842)92-23-67  
Кемерово (3842)65-04-62  
Киров (8332)68-02-04  
Коломна (4966)23-41-49  
Кострома (4942)77-07-48  
Краснодар (861)203-40-90  
Красноярск (391)204-63-61  
Курск (4712)77-13-04  
Курган (3522)50-90-47  
Липецк (4742)52-20-81

Магнитогорск (3519)55-03-13  
Москва (495)268-04-70  
Мурманск (8152)59-64-93  
Набережные Челны (8552)20-53-41  
Нижний Новгород (831)429-08-12  
Новокузнецк (3843)20-46-81  
Ноябрьск (3496)41-32-12  
Новосибирск (383)227-86-73  
Омск (3812)21-46-40  
Орел (4862)44-53-42  
Оренбург (3532)37-68-04  
Пенза (8412)22-31-16  
Петрозаводск (8142)55-98-37  
Псков (8112)59-10-37  
Пермь (342)205-81-47

Ростов-на-Дону (863)308-18-15  
Рязань (4912)46-61-64  
Самара (846)206-03-16  
Санкт-Петербург (812)309-46-40  
Саратов (845)249-38-78  
Севастополь (8692)22-31-93  
Саранск (8342)22-96-24  
Симферополь (3652)67-13-56  
Смоленск (4812)29-41-54  
Сочи (862)225-72-31  
Ставрополь (8652)20-65-13  
Сургут (3462)77-98-35  
Сыктывкар (8212)25-95-17  
Тамбов (4752)50-40-97  
Тверь (4822)63-31-35

Тольятти (8482)63-91-07  
Томск (3822)98-41-53  
Тула (4872)33-79-87  
Тюмень (3452)66-21-18  
Ульяновск (8422)24-23-59  
Улан-Удэ (3012)59-97-51  
Уфа (347)229-48-12  
Хабаровск (4212)92-98-04  
Чебоксары (8352)28-53-07  
Челябинск (351)202-03-61  
Череповец (8202)49-02-64  
Чита (3022)38-34-83  
Якутск (4112)23-90-97  
Ярославль (4852)69-52-93

Россия +7(495)268-04-70

Казахстан +7(7172)727-132

Киргизия +996(312)96-26-47

эл.почта: [taq@nt-rt.ru](mailto:taq@nt-rt.ru) || сайт: <https://teknokroma.nt-rt.ru/>

## New Generation HPLC Column



The **mediterranea sea<sub>18</sub>** column provides a performance level that, until now, has not been reached in efficiency, inertness, pH-robustness, reproducibility and reliability. **mediterranea sea<sub>18</sub>** columns simplify and make your HPLC work more pleasant. You won't worry about the extreme basic or acidic natures of your samples with the **mediterranea sea<sub>18</sub>** column.

The versatility of the **mediterranea sea<sub>18</sub>** column will enable you to deal successfully with the immense variety of separations in the fields of pharmaceuticals, life sciences, environment, foods, etc.

Once every ten years, the world of chromatography experiences a revolutionary technology that surpasses all others and meets the expectations of chromatographic scientists.

Teknokroma has focused all its efforts and all its know-how, accumulated through more than 25 years of chromatographic research and development, in offering the global-best reverse phase HPLC packing **mediterranea sea<sub>18</sub>**.

While developing the **mediterranea sea<sub>18</sub>** column we created two novel proprietary bonding & packing technologies. In order to demonstrate the global-best technology of **mediterranea sea<sub>18</sub>**, we compared chromatographic results from the world's most popular reverse-phase HPLC columns. We invite you to try our **mediterranea sea<sub>18</sub>** when you experience less-than-satisfactory results with your favourite column.

Today there is still a consensus about the fact that the best material to use as chromatographic packing continues to be silica. The particles of this material are very physically resistant, enable multiple functions, present maximum levels of efficiency and are also compatible with practically all solvents.

Teknokroma has been concentrated on obtaining the best silica particle in the market. The silica particle on which the **mediterranea sea<sub>18</sub>** column is based is the result of an optimisation process in which, starting off from extremely pure materials with unusual low metal content, a perfectly spherical, rigid and inert particle has been obtained. Furthermore, the "porification" process developed for these ends (Surface Enhanced Accessibility, SEA) has achieved a high surface without losing any of its properties of physical resistance while also showing a very high load capacity, ideal for preparatory scaled processes. Moreover, the obtained porous structure ensures the maximum transfer speed of the solutes between the stationary and mobile phases, resulting in a greater separation efficiency.

Let us demonstrate the superior chromatographic properties of the **mediterranea sea<sub>18</sub>** column, so you will feel comfortable with the performance of the world's best reverse-phase HPLC column.

## Purity of Silica

After evaluating many materials as a base for the global-best reverse phase chromatographic packing, the clear consensus is that the special characteristics of silica packings classify them as unsurpassable. No other packing material, apart from ultra-pure silica, achieves the perfect balance of physical resistance, functional use, chemical inertness, reproducibility and efficiency. Ultra-pure silica is also compatible with practically all solvents. Teknokroma concentrated on presenting the best silica particle to the HPLC market.

An essential condition for obtaining the global-best reverse phase packing is an extremely pure silica. The silica particle, on which the new **mediterranea sea<sub>18</sub>** packing is based, is obtained from ultra-pure materials, using rigorously controlled manufacturing processes to ensure that the slightest possibility of contamination is avoided. The **mediterranea sea<sub>18</sub>** silica required intensive optimisation of numerous processing factors to achieve a perfectly spherical, rigid and inert particle possessing unusually low metal content.

The almost total absence of metals is one of the pillars over which the extraordinary properties of the **mediterranea sea<sub>18</sub>** column reside.

Metals Content (ppm)	
Metal	Values Obtained
Al	<1ppm
Fe	<1ppm
Ti	<1ppm
Zr	<1ppm

## Porosity (Surface Enhanced Accessibility, SEA)

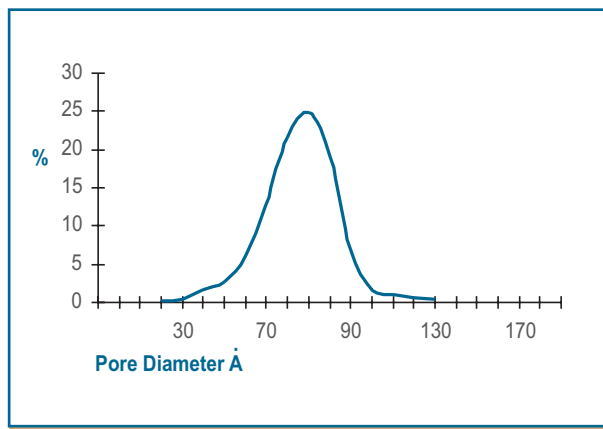

The pore distribution of the **mediterranea sea<sub>18</sub>** column has been optimised by our own proprietary process called Surface Enhanced Accessibility (Sea). The Surface Enhanced Accessibility "porification" process creates high surface area without losing silica structural strength, chemical resistance, chemical inertness and high load capacity. Surface Enhanced Accessibility also ensures that practically 100% of the internal packing surface has been chemically bonded, endcapped, and is accessible to compounds being separated. Moreover, the Surface Enhanced Accessibility of **mediterranea sea<sub>18</sub>** ensures the maximum transfer speed of the solutes between the stationary and mobile phases, resulting in a greater separation efficiency.

More than 98% of the silica surface area responsible for chromatographic separation of the sample is found inside the particle - within the pores. This explains the extreme importance of obtaining a very homogeneous pore distribution and the least possible number of nanopores. For most reverse-phase silica packings, these nanopores are not properly chemically bonded, endcapped or deactivated. So when nanopores are accessible to analytes, surface-analyte interactions frequently dominate. These surface-analyte interactions slow down the chromatographic process ("load transfer"), often resulting in decreased column efficiency. These treacherous nanopores may also negatively influence the phenomenon of dewetting which occurs with totally aqueous mobile phases.

## Multifunctional Endcapping Deactivation (MED)

The endcapping process is a critical step in obtaining a perfectly deactivated **mediterranea sea<sub>18</sub>** column. Our proprietary Multifunctional Endcapping Deactivation (MED) technology maximizes surface-bonding, blocking practically all the active centres that may have remained on the surface of the silica after bonding the C18 chains. Thanks to our new MED technology, the **mediterranea sea<sub>18</sub>** column enjoys an unusual low level of silanol activity - helping you to obtain symmetrical peaks from even the most basic and acidic pharmaceuticals and their metabolites. **mediterranea sea<sub>18</sub>** bonding chemistries will help you to achieve an extraordinary resistance and column lifetime when running at extreme pH levels.

Moreover, the **mediterranea sea<sub>18</sub>** column has been designed to show an excellent retention of polar compounds in a 100% aqueous environment without the problems of unwanted interactions which inefficiently endcapped conventional packings produce. Packing chemistry based on the new MED technology, "multifunctional endcapping deactivated", achieves levels of deactivation, resistance to extreme pH values and versatility in its chromatographic applications never reached by conventional or polar-embedded reverse phase packings. The MED technology has been rigorously developed to achieve the maximum reproducibility, with the objective that its chromatographic separations will be, column to column, exactly the same.

The obtained deactivation is shown when we make chromatograms of a group of Basic compounds in neutral pH conditions, including a neutral compound (acenaphthene) as a comparison. Of the four tested columns, the **mediterranea sea<sub>18</sub>** is the one that shows the greatest efficiency, whether measuring with the acenaphthene or with a peak as difficult as that of amitriptyline. The same occurs if we compare the asymmetry values of the peaks.

Column	As Acenaphthene	Ncol Acenaphthene	As Amitriptyline	Ncol Amitriptyline
<b>mediterranea sea<sub>18</sub></b>				
5um 15x0,46	<b>1,06</b>	<b>11031</b>	<b>1,21</b>	<b>8119</b>
Xterra MSC18 5um 15x0,39	1,36	6476	1,32	4619
Gemini C18 5um 15x0,46	1,22	9524	1,23	7490
Nucleosil 100 C18 5um 15x0,46	1,07	7815	na	na

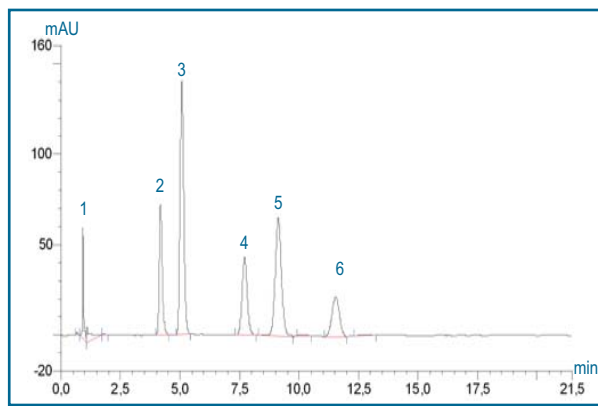

### TRICYCLIC ANTI-DEPRESSANTS

Column: **mediterranea sea<sub>18</sub>** 5 μm 15 x 0,46 cm  
 Eluent: Methanol/20mM K<sub>2</sub>HPO<sub>4</sub>(pH 7.0) 70:30  
 Flow: 1ml/min  
 Room Temperature  
 Detection: UV 254 nm

#### Peaks:

1. Desipramine
2. Nortriptyline
3. Acenaphthene
4. Imipramine
5. Amitriptyline
6. Trimipramine

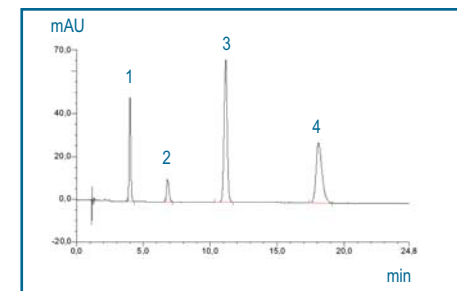

Column A

**mediterranea sea<sub>18</sub>**

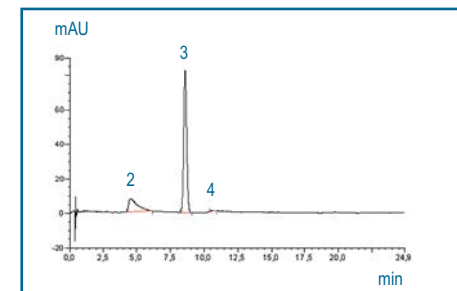

Column B

**The Competition**

### BASIC COMPOUNDS

Column A: **mediterranea sea<sub>18</sub>** 5 μm 15 X 0,46 cm  
 Column B: Other column from market 5 μm 15 x 0,46 cm  
 Eluent: Methanol/0,02M K<sub>2</sub>HPO<sub>4</sub>/KH<sub>2</sub>PO<sub>4</sub> pH7,00 (75:25)  
 Room temperature  
 Flow: 1.4ml/min  
 Detection: UV 254 nm

#### Composition of test solution:

1. Propranolol
2. Diphenhydramine
3. Acenaphthene
4. Amitriptyline

## Aqueous Environments

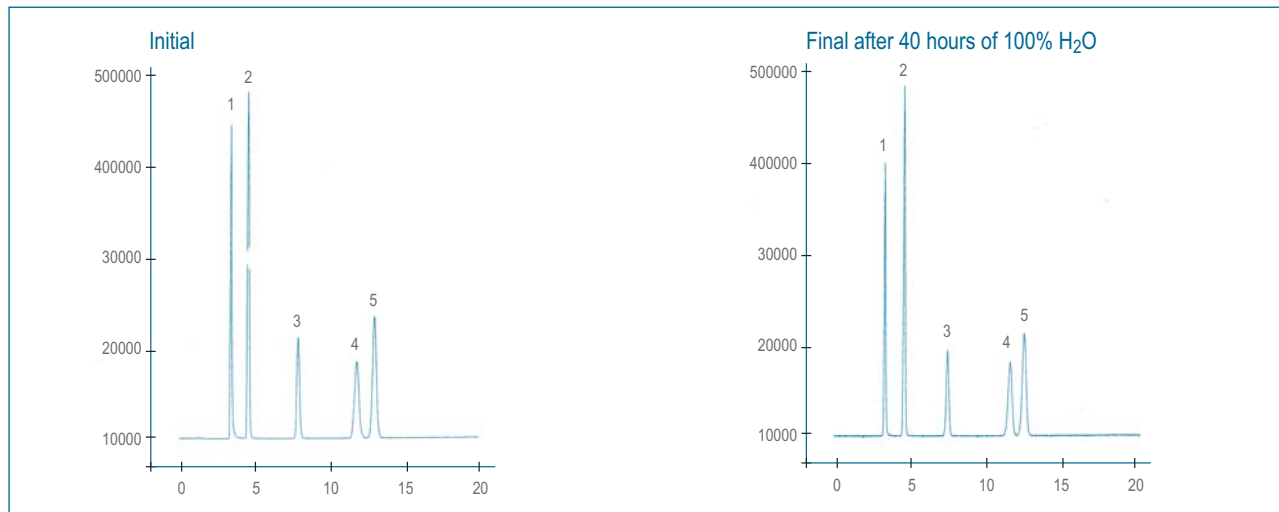

### AQUEOUS ENVIRONMENTS

Column: **mediterranea sea<sub>18</sub>** 5 μm 15 X 0,46 cm  
 Movil Phase: H<sub>2</sub>O  
 Flow: 1ml/min  
 Vol. Iny.: 10ul  
 Detección: UV 254 nm

#### Peaks:

1. Cytosine
2. Uracil
3. Cytidine
4. Uridine
5. Thymine

The **mediterranea sea<sub>18</sub>** packing is a 100% pure reverse phase with the added advantage of showing excellent retention of polar compounds and also enables work with 100% aqueous mobile phases without any limitation.

Most chromatographers agree that polar embedded packing have an advantage over conventional packings; in that they can work in 100% aqueous environments and separate basic compounds.

Nevertheless, these advantages are achieved at the expense of less retention for polar compounds, and poor column stability. Polar-embedded packings exhibit chromatographic behavior that cannot be considered as 100% reverse phase, since secondary interaction mechanisms may co-exist due to the nature of the unspecified polar groups anchored at the base of the hydrocarbon chains.

The **mediterranea sea<sub>18</sub>** packing surpasses all the advantages of polar embedded packings by a wide margin and shows none of its inconveniences.

Furthermore, due to its specially optimised endcapping process (MED), the column has guaranteed pH-resistance, reproductibility and long life.

As can be seen, the chromatograms that are obtained after eluting the column with 100% water for more than 40 hours show no appreciable alteration in the retention times or in the efficiency of the chromatographed peaks.

The **mediterranea sea<sub>18</sub>** column also widely surpasses the stop flow test, designed to be able to show up the dewetting phenomenon that usually occurs in highly deactivated ODS-type columns, causing irreversible expulsion of water included in the packing pores. As can be seen in the data of five successive Stop Flow Test cycles no significant alterations are observed in the chromatographed peaks.

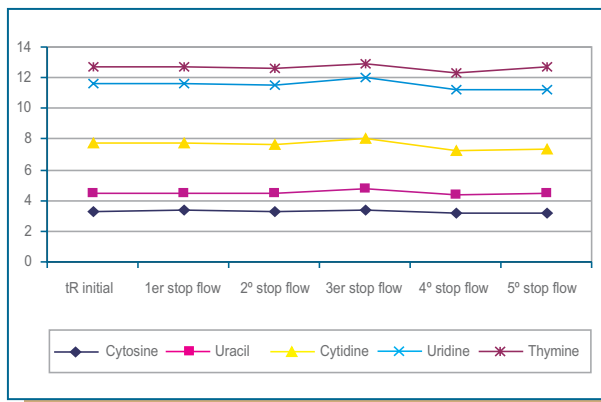

### The phenomenon of "Dewetting"

When working with mixed mobile phases of an organic phase and water, for example Methanol/H<sub>2</sub>O, the pores of the packings are totally occupied with the mobile phase (A). However, when working with 100% H<sub>2</sub>O as the mobile phase in conventional reverse-phase columns, a phenomenon occurs with the expulsion of the mobile phase from the interior of the pore (B). The chromatographic effect that will be produced is a loss of retention and resolution of the chromatographic peaks since the solutes cannot enter the interior of the pores. These chromatographic losses can occur gradually or suddenly - making it difficult to restore to its initial conditions, especially with mostly aqueous mobile phases. (C).

This phenomenon is ruled by an equation which involves the pore's radius, the surface tension, the contact angle and the pressure exercised on the mobile phase. The surface tension and contact angle depends on the density of the bonded ligands and on their chemical functionality. The Stop Flow Test reproduces chromatographic run conditions by interrupting the flow of 100% aqueous mobile phase, the pressure goes to zero and favours the expulsion of water from the interior of the pores.

The **mediterranea sea<sub>18</sub>** column surpasses this test with ease - the retention times of the five chromatographed compounds remain practically unaltered.

Compound	tR initial	1st stop flow	2nd stop flow	3rd stop flow	4th stop flow	5th stop flow
Cytosine	3,32	3,33	3,3	3,35	3,16	3,21
Uracil	4,45	4,45	4,44	4,75	4,36	4,44
Cytidine	7,73	7,73	7,63	8,00	7,24	7,34
Uridine	11,57	11,57	11,53	12,02	11,25	11,24
Thymine	12,70	12,7	12,62	12,87	12,35	12,70

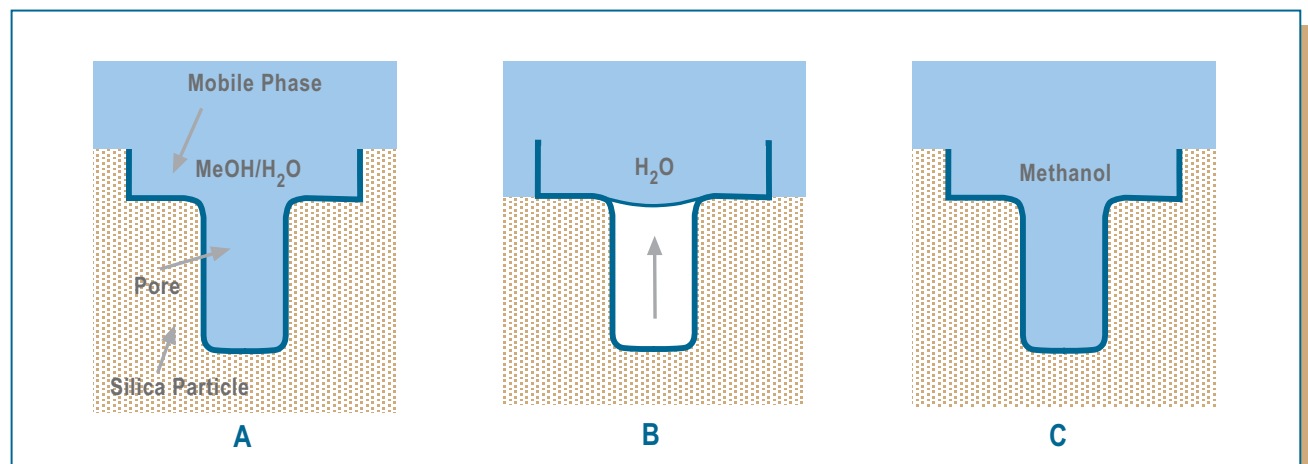

## NIST Test for HPLC Packing Characterization

The new **mediterranea sea<sub>18</sub>** column has been subjected to the SRM870 test. This test, designed by the NATIONAL INSTITUTE OF STANDARDS & TECHNOLOGY and recently assessed by the experts committee of the USP (United States Pharmacopeia) is currently considered to be the most recommended for evaluating the most significant properties of a reverse phase column.

The high number of HPLC reverse phase packings available in the market and the big differences in their chromatographic behaviour has led to the need to design a characterisation and classification method for these packings.

This procedure uses a mixture of five organic components (uracil, toluene, ethylbenzene, quinizarin and amitriptyline) which are chromatographed using exact conditions of mobile phase, flow, and controlled temperatures.

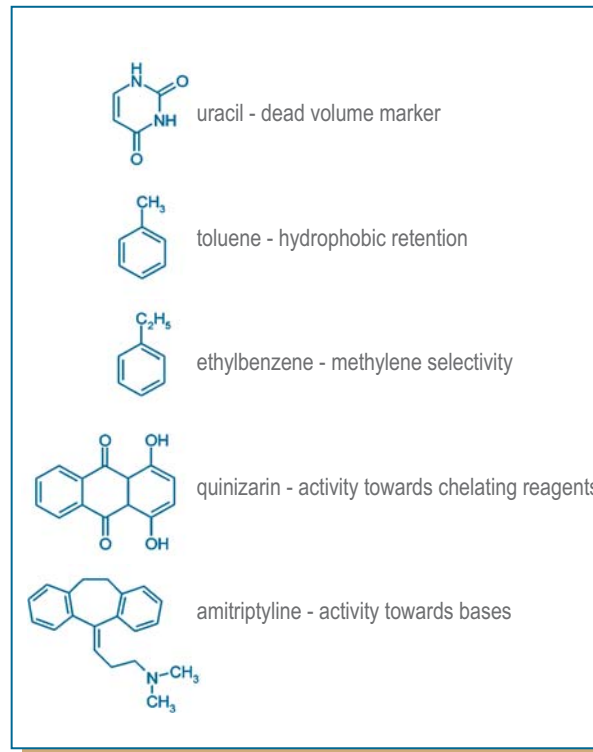
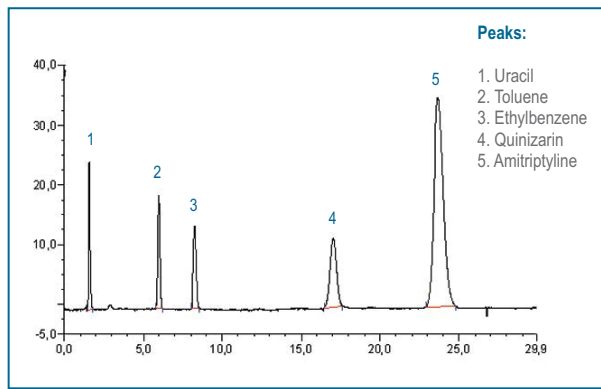

The detailed analysis of the different peaks obtained will enable an objective, and more importantly, standardised evaluation of the behaviour of the chromatographic packing and therefore anticipate its suitability in normal analytical work.

### Uracil

This compound is commonly used as an indicator of the dead volume of the column (non-retained peak).

### Toluene/Ethylbenzene

The selectivity factor between these two compounds can be used to characterise the differences between packings primarily due to solvophobic interactions. The absolute retention times of these compounds give an idea of the column reverse-phase strength.

Both compounds can also be used to measure the quality of the packing through the number of theoretical plates.

## Quinizarin (1,4-dihydroanthraquinone)

Quinizarin is a chelating compound and its behaviour in a reverse phase column is a clear indicator of the presence or absence of metals. A column of low activity will deliver symmetrical peaks whereas increasing surface activity exaggerates the tailing edge of the quinizarin peak - leading to higher asymmetry values. Quinizarin normally elutes between the ethylbenzene and amitriptyline peaks. However, when the silica packing contains embedded polar groups they will retain this peak, causing it to elute after amitriptyline.

In the **mediterranea sea<sub>18</sub>** column, the quinizarin peak elutes with a perfect symmetrical form, indicating an extraordinary low level of metallic impurities.

According to quinizarin peak symmetry data obtained in our laboratories or published by the NIST (see Figure), the performance of the **mediterranea sea<sub>18</sub>** column compares well with other popular reverse-phase packings.

The top-positioning of the **mediterranea sea<sub>18</sub>** packing indicates the ultra-high purity of the optimized silica. Teknokroma's ultra-pure silica is your guarantee of reproducibility and of the absence of secondary (and uncontrolled) mechanisms of interaction (common to popular polar-embedded columns).

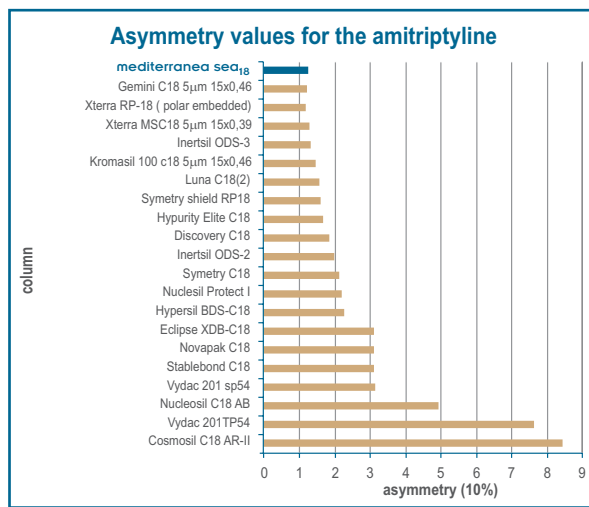
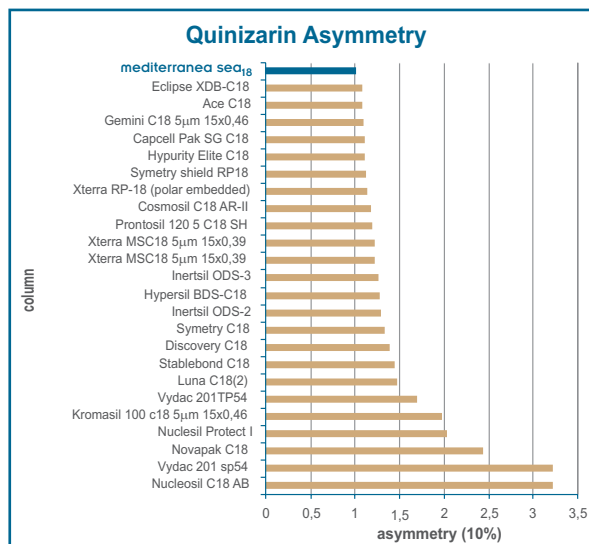

## Amitriptyline

This basic (pKa=9.4) anti-depressant is an excellent indicator of residual silica surface silanol-activity. Amitriptyline will elute as a symmetrical peak on a well-deactivated column as seen with the new **mediterranea sea<sub>18</sub>**. In comparison, many popular reverse-phase packings leave many residual silanols through insufficient endcapping; leading to widespread peak tailing or to complete disappearance from the chromatogram.

Proper amitriptyline elution is important in consideration of the number of basic compounds, particularly in the fields of pharmaceuticals and life science. In fact, it guarantees that the problems with tailing or complete peak disappearance will be almost eradicated - along with day-to-day laboratory adjustments and complex mobile phase systems designs. With **mediterranea sea<sub>18</sub>** a simple pH adjustment will serve to correctly elute the most basic and acidic substances.

The comparison of asymmetry factors for **mediterranea sea<sub>18</sub>** and other popular packings is a clear indication of deactivation. **mediterranea sea<sub>18</sub>** enters the market with a deactivation level not previously achieved by other reverse-phase packings. The proprietary Multifunctional Endcapped Deactivation produces reproducible column-to-column peak symmetry for a wider variety of pharmaceutical compounds thanks to strict silica purity and batch-to-batch reproducibility.

## Wide pH Range

A perfectly spherical particle, a totally controlled pore design, a total lack of metallic traces, a well-studied process of phase bonding and final endcapping, all combine in achieving a packing with a resistance to extreme pH values not previously reached.

Until quite recently, silica packings were limited to working between pH 2 and pH 7 since below pH 2 the bonds between the C18 chains and the silica particle were hydrolysed, resulting in a gradual loss of retention capacity of the column. Above pH 7 the problem that arose was one of simply dissolving the silica, and therefore the pure destruction of the column.

Using **mediterranea sea<sub>18</sub>** packing makes it possible to work with eluents from pH 1 to pH 12. Such unusual pH-resistance values have been secured as a result of phase bonding efficiency and a proprietary endcapping process which provides a protective shield that impedes acidic and basic eluents from attacking the silica surface.

The pH stability graphs show the efficiency of the process.

Eluting the **mediterranea sea<sub>18</sub>** column for 78 hours at pH 11.5, showed no significant deterioration in terms of both efficiency and peak symmetry for diphenhydramine..

With an eluent as acid as pH 1, the column stabilises in a short period of time so that it will even be possible to work in these extreme conditions.

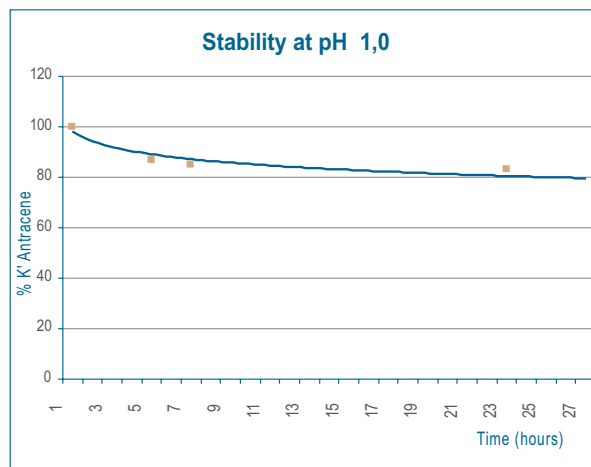

An eluent of ACN/TFA1% pH 1.0 (10:90) 1ml/min 25°C is passed through the column at regular periods, checked with the reverse phase test and a retention comparison is made of the last anthracene peak.

An eluent of ACN/1- methylpyrrolidine 50mM pH 11,5 50:50, 1ml/min 25°C is passed through the column. With the same eluent 10 µl of diphenhydramine (1mg/ml dissolved in water) is injected and the efficiency and symmetry of the peak is tested.

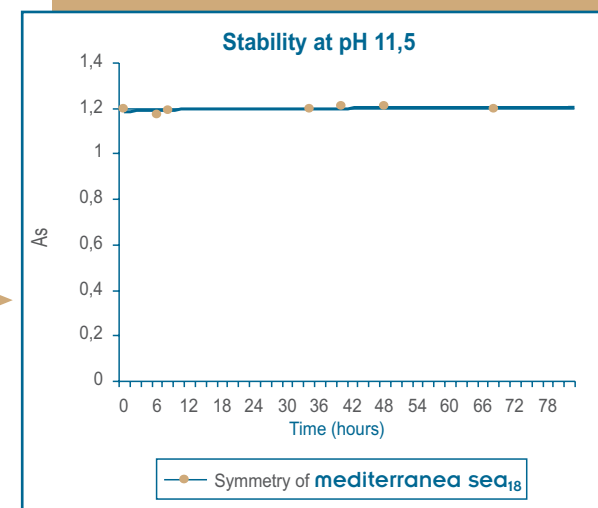
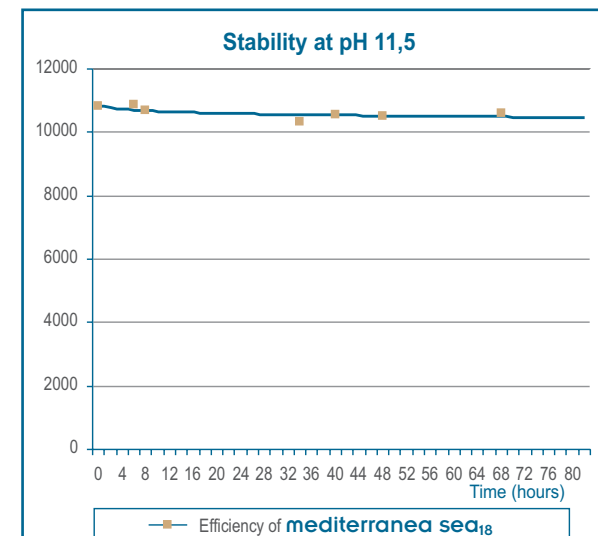



## LC-MS Mediterranean Sea 18 Columns

The Multifunctional Endcapping Deactivation (MED) technology guarantees extreme stability for every **mediterranea sea<sub>18</sub>** reverse-phase column. Chromatographic stability (peak symmetry, peak retention times, and peak efficiency) under low-to-high pH (pH 1-12) conditions is required for high-speed, high-throughput LC-MS. The **mediterranea sea<sub>18</sub>** is the ideal LC-MS reverse-phase column for stable chromatographic separation of pharmaceuticals and their metabolites.

The technological features designed into the **mediterranea sea<sub>18</sub>** column makes it extremely useful for LC-MS applications where packing stability is demonstrated by low column bleed and consistent chromatographic results. The combination of **mediterranea sea<sub>18</sub>** technology on a 3µm ultra-pure silica-based packing enables LC-MS separations to be made speedily and with maximum productivity.



### Bleeding Profile Comparison

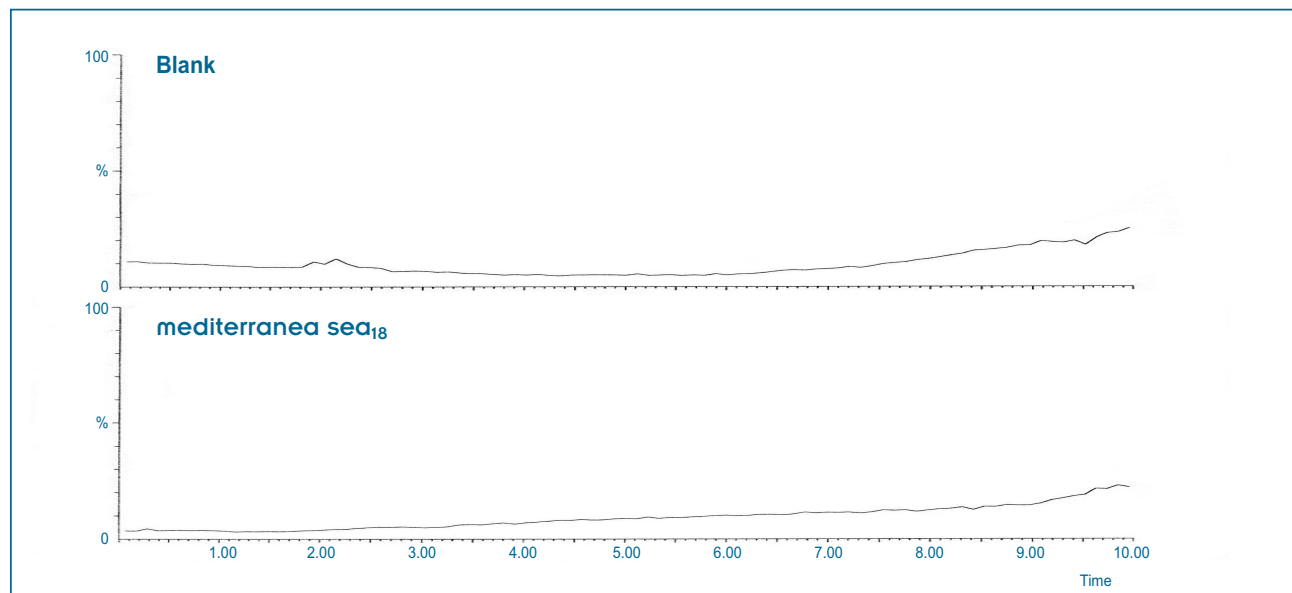

Assay by Instituto Químico de Sarriá I.Q.S. (Barcelona)

### Chromatographic Conditions

Mobile Phase: A: CH<sub>3</sub>CN (0,1% formic acid)  
B: Water (0,1% formic acid)  
Elution Gradient: 5/95(A/B) linear up to 95:5 in 8 minutes, maintaining the final composition 2 minutes.  
Flow: 0,5mL/min  
Column Temperature: 25°C

### Conditions for MS Detection

MS Instrument: Waters ZMD  
Capillary Voltage: 3kV (ESI positive)  
Cone Voltage: 20V  
Source block Temp: 100°C  
Desolvation Temp: 350°C  
Gas: 500l/h  
Gas of cone: 35 l/h  
Mass Range: 60 to 100 amu

## Ultra-Rapid Columns

Within the wide range of possible configurations, the **mediterranea sea<sub>18</sub>** columns are available with 3 μm packing with lengths of 3, 5 and 10 cm and inner diameters of 2.1, 3.0, 4.0 and 4.6 mm. By maintaining high quality control and specifications in manufacturing the **mediterranea sea<sub>18</sub>** packing, these columns enable you to do ultra-fast separations, with extremely high levels of productivity and reduced analysis times. Ultrarapid **mediterranea sea<sub>18</sub>** columns will help you optimize your instrument time and give you more time to analyze data.

With Ultra-rapid column separations, total analysis times of less than one minute are common, even when using gradient elution methods, since the high porosity of the **mediterranea sea<sub>18</sub>** packing enables rapid mobile phase equilibration times.

The combination of 3 μm **mediterranea sea<sub>18</sub>** packing with the column diameter of 2.1 mm is recommended for high sensitivity LC/MS analyses. Many of these ultra-rapid LC-MS screening analyses utilize minute sample and solvent quantities - for which, the 3 μm **mediterranea sea<sub>18</sub>** columns are ideal.

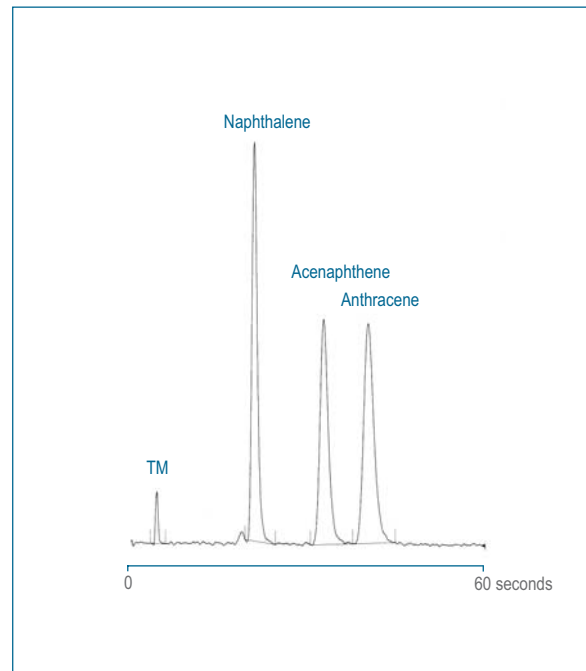

### Chromatographic Conditions

Column: **mediterranea sea<sub>18</sub>**  
 3 μm 3 x 0,46 cm  
 Eluant: Acetonitrile/Water  
 Proportion: 65/35  
 Flow: 3.0 ml/min  
 Pressure: 70 bars  
 Vol Injection: 0.5 μl  
 Temperature: Room  
 Detección: UV 254 nm

### Composition of Test Solution

Uracil (TM) 0.002 mg/ml  
 Naphthalene 0.100 mg/ml  
 Acenaphthene 0.200 mg/ml  
 Anthracene 0.004 mg/ml

## Preparative Columns



The **mediterranea sea<sub>18</sub>** columns are characterized by their total inertness, by their wide range of working mobile phase pH, and by their high loading capacity - a result of the SEA process control (Surface Enhanced Accessibility).

The **mediterranea sea<sub>18</sub>** preparative columns are the natural choice when high-service preparative columns are required, and in high-speed preparative applications as in the case of Combinatorial Chemistry.

## New Hardware Design for Mediterranea Column: Ultrafit™ System

The new Ultrafit™ design will make your work in the laboratory more comfortable and efficient. The Ultrafit™ system, as well as helping in the replacement of the frit at the column entrance, enables you to easily include either additional frits or a pre-column, always with the utmost simplicity and economy and in no way whatsoever is the quality of the separation affected.

In designing the Ultrafit™ column, the greatest care has been taken to cover all the aspects that may occur in the loss of efficiency of the column. As a result of all this, dead volumes have been reduced to a minimum, entered by the system by means of a high precision

mechanism, with inlet and outlet holes of 0.2 mm and first-class tapers for the perfect distribution of the inlet and outlet flows, as seen in the three depicted Ultrafit™ options. The Ultrafit™ system enables a pre-column to be included without loss of efficiency, to columns as small as 30 x 4 mm packed with particles of 3 μm.

Moreover, the very best material has been selected for the construction of the column, with an ultra-shiny interior finish, of extremely low RMS, ensuring that no tube imperfection in the column will affect the quality of the separation.

Ultrafit™ System efficiency		
	Efficiency (N/m)	AS (10%)
mediterranea sea <sub>18</sub> Column 3 μm 5 x 0,46 cm Ultrafit™ System	134904	1,11
mediterranea sea <sub>18</sub> Column 3 μm 5 x 0,46 cm with Prefilter Ultrafilter™	135042	1,05
mediterranea sea <sub>18</sub> Column 3 μm 5 x 0,46 cm with Precolumn Ultraguard™	137819	1,07

**Chromatographic Conditions:**

Column: **mediterranea sea<sub>18</sub>** 3 μm 5 x 0,46 cm  
 Eluant: Acetonitrile/Water 65:35  
 Flow: 0,9 ml/min  
 Det. UV 254 nm  
 Temp. Room  
 Sample: Acenaphthene 0,2 mg/ml

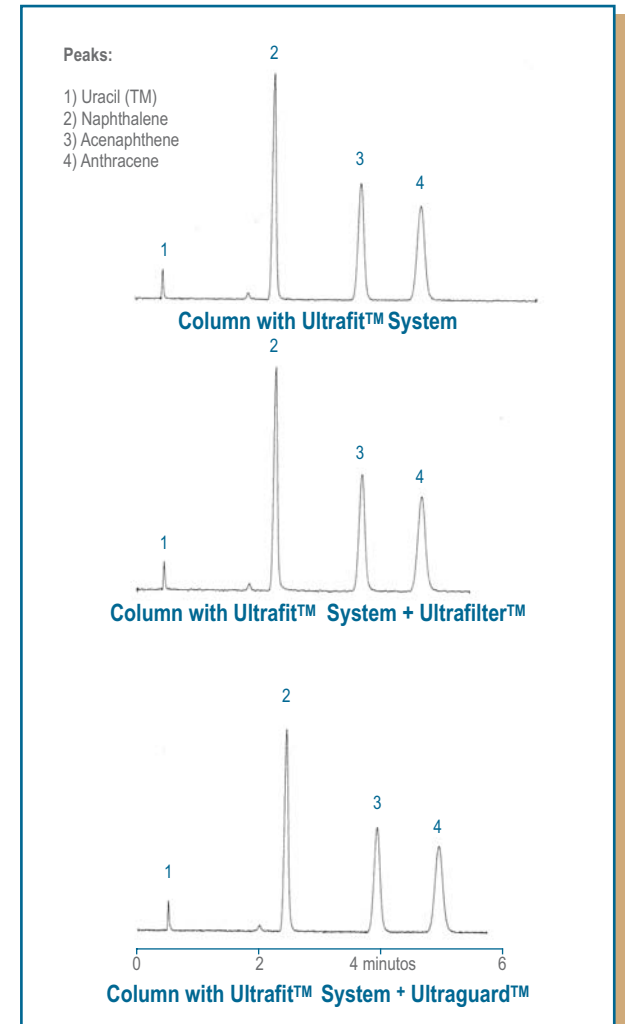

■ Ultrafit™ System Configuration

Ultrafit™

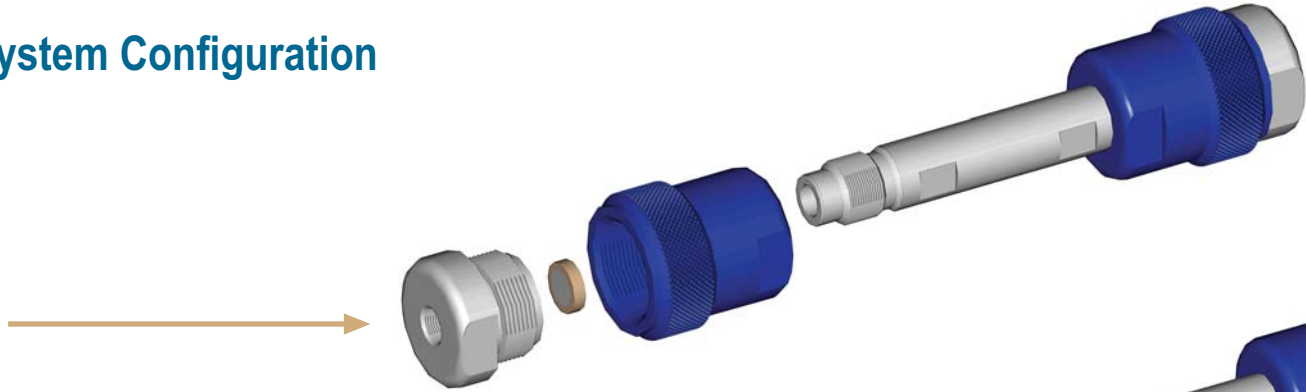

Ultrafit™ + Ultrafiter™

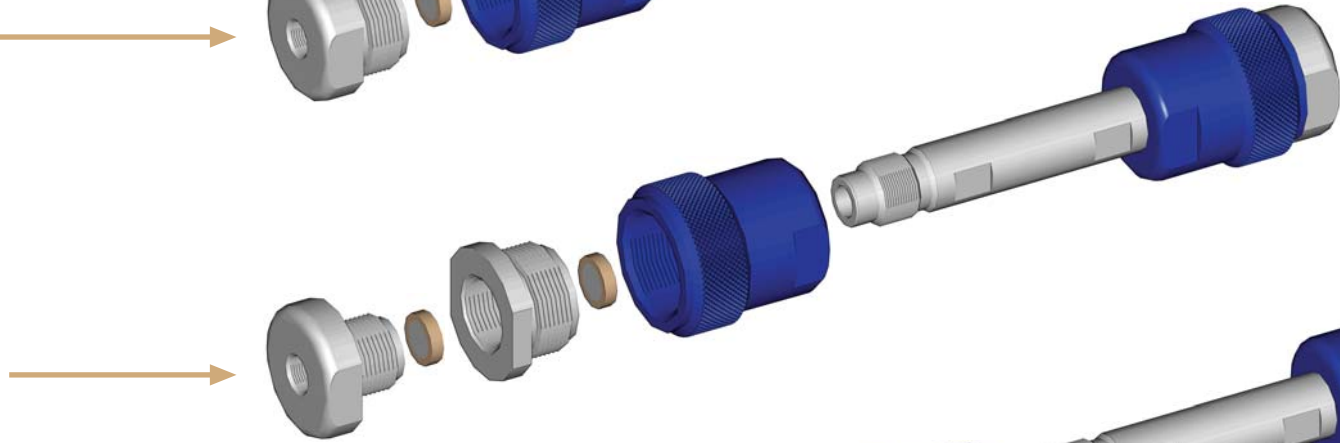

Ultrafit™ + Ultraguard™

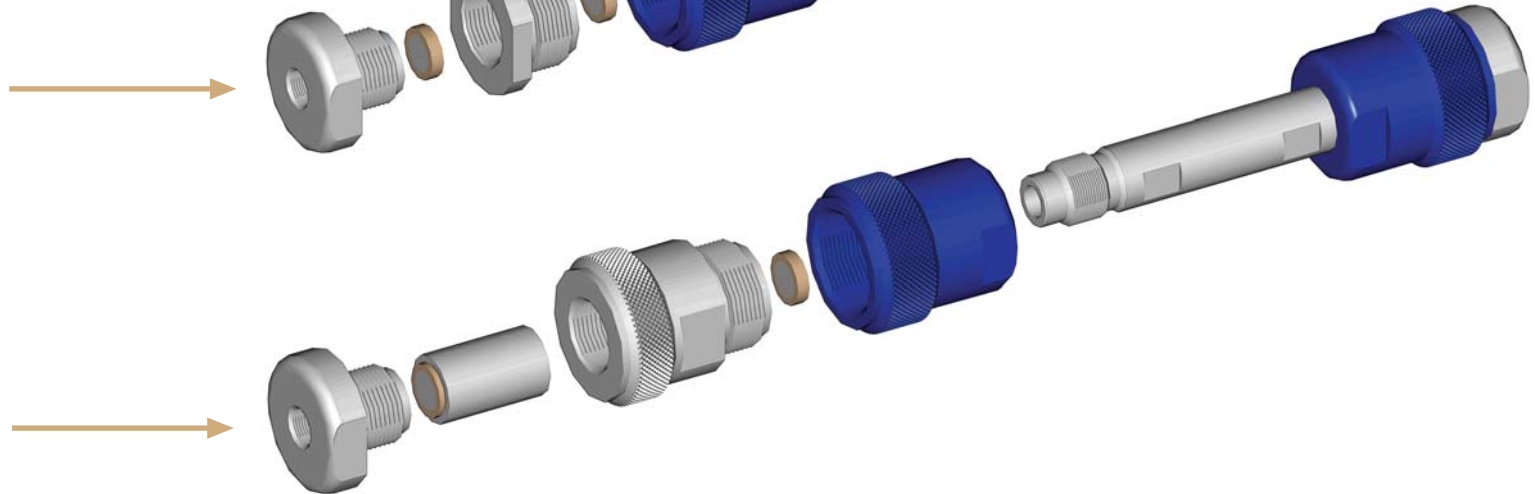



## Product List

### ANALYTICAL COLUMNS 4,6 mm i.d. mediterranea sea<sub>18</sub> 5 µm

		L e n g t h						
Function µm		3 cm	4 cm	5 cm	10 cm	15 cm	20 cm	25 cm
Sea 18	5	TR-010000	TR-010001	TR-010002	TR-010003	TR-010004	TR-010005	TR-010006

### ANALYTICAL COLUMNS 4,0 mm i.d. mediterranea sea<sub>18</sub> 5 µm

		L e n g t h						
Function µm		3 cm	4 cm	5 cm	10 cm	15 cm	20 cm	25 cm
Sea 18	5	TR-010007	TR-010008	TR-010009	TR-010010	TR-010011	TR-010012	TR-010013

### ANALYTICAL COLUMNS 2,1 mm i.d. mediterranea sea<sub>18</sub> 5 µm

		L e n g t h				
Function µm		3 cm	5 cm	10 cm	15 cm	20 cm
Sea 18	5	TR-010014	TR-010015	TR-010016	TR-010017	TR-010018

### ANALYTICAL COLUMNS 3,0 mm i.d. mediterranea sea<sub>18</sub> 5 µm

		L e n g t h					
Function µm		3 cm	5 cm	10 cm	15 cm	20 cm	25 cm
Sea 18	5	TR-010019	TR-010020	TR-010021	TR-010022	TR-010023	TR-010024

### CARTRIDGE SYSTEM 4 mm i.d. mediterranea sea<sub>18</sub> 5 µm

		L e n g t h			
Function µm		7.5 cm	10 cm	15 cm	25 cm
Sea 18	5	TR-010035	TR-010036	TR-010037	TR-010038

### ULTRA-RAPID ANALYTICAL COLUMNS 4,6 mm i.d. mediterranea sea<sub>18</sub> 3 µm

		L e n g t h						
Function µm		3 cm	4 cm	5 cm	10 cm	15 cm	20 cm	25 cm
Sea 18	3	TR-010039	TR-010040	TR-010041	TR-010042	TR-010043	TR-010044	TR-010045

### ULTRA-RAPID ANALYTICAL COLUMNS 4,0 mm i.d. mediterranea sea<sub>18</sub> 3 µm

		L e n g t h						
Function µm		3 cm	4 cm	5 cm	10 cm	15 cm	20 cm	25 cm
Sea 18	3	TR-010046	TR-010047	TR-010048	TR-010049	TR-010050	TR-010051	TR-010052

### ULTRA-RAPID ANALYTICAL COLUMNS 2,1 mm i.d. mediterranea sea<sub>18</sub> 3 µm

		L e n g t h				
Function µm		3 cm	5 cm	10 cm	15 cm	20 cm
Sea 18	3	TR-010053	TR-010054	TR-010055	TR-010056	TR-010057

### ULTRA-RAPID ANALYTICAL COLUMNS 3,0 mm i.d. mediterranea sea<sub>18</sub> 3 µm

		L e n g t h				
Function µm		3 cm	5 cm	10 cm	15 cm	20 cm
Sea 18	3	TR-010058	TR-010059	TR-010060	TR-010061	TR-010062

### CARTRIDGE SYSTEM 4 mm i.d. mediterranea sea<sub>18</sub> 3 µm

		L e n g t h			
Function µm		7,5 cm	10 cm	15 cm	25 cm
Sea 18	3	TR-010063	TR-010064	TR-010065	TR-010066





## Product List

### SEMI-PREPARATIVE COLUMNS mediterranea sea<sub>18</sub> 5 μm

Function	μm	mm. id	L e n g t h			
			5 cm	10 cm	15 cm	25 cm
Sea 18	5	7,0	-	TR-010025	TR-010026	TR-010027
Sea 18	5	1,0	-	TR-010028	TR-010029	TR-010030
Sea 18	5	21,2	TR-010031	TR-010032	TR-010033	TR-010034

### OTHER PRODUCTS mediterranea sea<sub>18</sub>

Ultrafilter™, Ultrafit prefilter adaptor

TR-010067



Ultraguard™, Ultrafit Guardcolumn adaptor

TR-010068



Frits of 0,5 μm pore (10 units)

TR-010069

Frits of 2,0 μm pore (10 units)

TR-010070

Ultraguard™ Sea18 10 x 3,2 mm (5 units)

TR-010071



Teknokroma HPLC R&D Department

## По вопросам продаж и поддержки обращайтесь:

Алматы (7273)495-231  
Ангарск (3955)60-70-56  
Архангельск (8182)63-90-72  
Астрахань (8512)99-46-04  
Барнаул (3852)73-04-60  
Белгород (4722)40-23-64  
Благовещенск (4162)22-76-07  
Брянск (4832)59-03-52  
Владивосток (423)249-28-31  
Владикавказ (8672)28-90-48  
Владимир (4922)49-43-18  
Волгоград (844)278-03-48  
Вологда (8172)26-41-59  
Воронеж (473)204-51-73  
Екатеринбург (343)384-55-89

Иваново (4932)77-34-06  
Ижевск (3412)26-03-58  
Иркутск (395)279-98-46  
Казань (843)206-01-48  
Калининград (4012)72-03-81  
Калуга (4842)92-23-67  
Кемерово (3842)65-04-62  
Киров (8332)68-02-04  
Коломна (4966)23-41-49  
Кострома (4942)77-07-48  
Краснодар (861)203-40-90  
Красноярск (391)204-63-61  
Курск (4712)77-13-04  
Курган (3522)50-90-47  
Липецк (4742)52-20-81

Магнитогорск (3519)55-03-13  
Москва (495)268-04-70  
Мурманск (8152)59-64-93  
Набережные Челны (8552)20-53-41  
Нижний Новгород (831)429-08-12  
Новокузнецк (3843)20-46-81  
Ноябрьск (3496)41-32-12  
Новосибирск (383)227-86-73  
Омск (3812)21-46-40  
Орел (4862)44-53-42  
Оренбург (3532)37-68-04  
Пенза (8412)22-31-16  
Петрозаводск (8142)55-98-37  
Псков (8112)59-10-37  
Пермь (342)205-81-47

Ростов-на-Дону (863)308-18-15  
Рязань (4912)46-61-64  
Самара (846)206-03-16  
Санкт-Петербург (812)309-46-40  
Саратов (845)249-38-78  
Севастополь (8692)22-31-93  
Саранск (8342)22-96-24  
Симферополь (3652)67-13-56  
Смоленск (4812)29-41-54  
Сочи (862)225-72-31  
Ставрополь (8652)20-65-13  
Сургут (3462)77-98-35  
Сыктывкар (8212)25-95-17  
Тамбов (4752)50-40-97  
Тверь (4822)63-31-35

Тольятти (8482)63-91-07  
Томск (3822)98-41-53  
Тула (4872)33-79-87  
Тюмень (3452)66-21-18  
Ульяновск (8422)24-23-59  
Улан-Удэ (3012)59-97-51  
Уфа (347)229-48-12  
Хабаровск (4212)92-98-04  
Чебоксары (8352)28-53-07  
Челябинск (351)202-03-61  
Череповец (8202)49-02-64  
Чита (3022)38-34-83  
Якутск (4112)23-90-97  
Ярославль (4852)69-52-93

Россия +7(495)268-04-70

Казахстан +7(7172)727-132

Киргизия +996(312)96-26-47

эл.почта: [taq@nt-rt.ru](mailto:taq@nt-rt.ru) || сайт: <https://teknochroma.nt-rt.ru/>